

Indirect Cooler Module Users Manual

Model IM70

2 Stage Evaporative Cooling

The IM70 indirect cooling module (ICM) is a pre-cooler used in 2-Stage or Indirect/Direct evaporative cooling. The ICM cools the air without adding any additional moisture. It accomplishes this by circulating water downward through a heat exchanger, while a fan draws air upward through the heat exchanger. This air and water are cooled by evaporation and in turn cool the walls of the heat exchanger. The removed heat is exhausted from the unit with the moist air. Hot, dry outside air is pulled horizontally through the cooled walls of the heat exchanger by the attached evaporative cooler. This air is cooled and since it does not contact water, there is no moisture added.

The dry air cooled by the ICM is then cooled more by the direct evaporative cooler. The dry bulb temperature of the air after going past the ICM drops as does the wet bulb or saturation temperature. This cooled dry air from the ICM is pulled through wet evaporative media in the direct evaporative cooler which cools the air and adds moisture. The temperature leaving the evaporative cooler is lower than what is possible without the ICM, often below the ambient wet bulb temperature.

The IM70 can be mounted directly to Champion's Ultracool 51 & 71 series evaporative cooler models for a complete 2-stage evaporative cooling process.

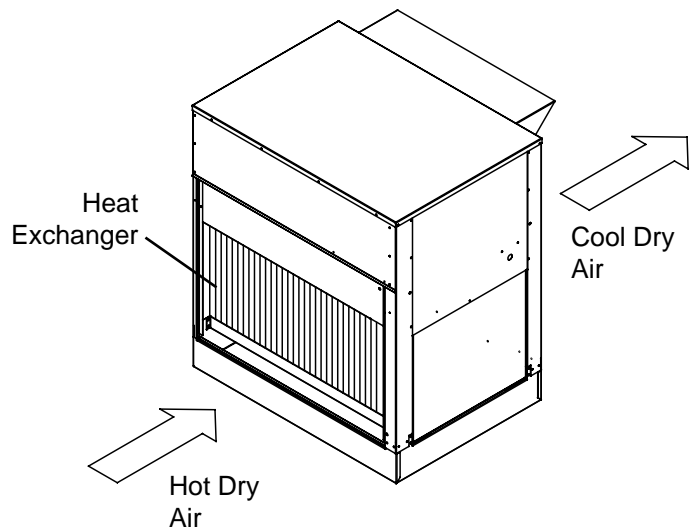

Safety Rules

1. Read instructions carefully.
2. Electrical hook up should be done by a qualified electrician, so that all electrical wiring will conform to your local standards.
3. Always Disconnect from Power Source before installing or performing any maintenance.
4. The IM70 will run on 120V A.C., single phase, 60 Hz (cycle) current only.
5. The pump and motor are equipped with an automatic thermal overload switch which will shut motor off when it overheats. The motor may start unexpectedly after it cools down.

Installation

⚠ CAUTION: Make sure that the mounting surface is strong enough to support the operating weight of the cooler when in use. (For operating weight, see Specification Table.)

⚠ CAUTION: Never start cooler until installation is complete and unit has been tested for rigidity.

- **Install rain guard.** A 3 piece rain guard kit is included with the unit. Refer to figure 1 for installation instructions. Place the flange of the top piece over the side piece and screw together with the provided screws. Repeat for both left and right sides. Slide the flange of the top section under the top pan. Screw the sides of the rain guard into the holes in the exhaust panel.

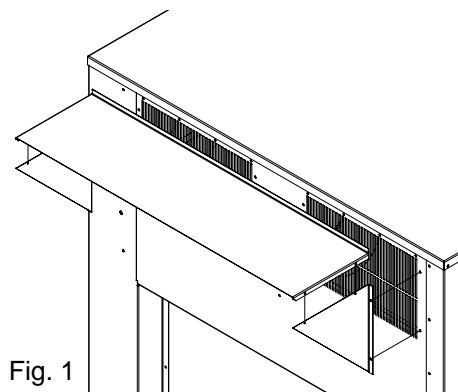

- **Mount unit to the evaporative cooler.** For two stage evaporative cooling, attach the IM70 to an Ultracool 51 or 71 unit (sold separately). Remove the perforated grill on the Ultracool. Attach weather stripping (not supplied) around the perimeter of the Ultracool. Slide the IM70 next to the cooler making sure the units fit snugly together. Using the provided mounting brackets and self drilling screws, locate the bracket below the top of the inspection panel on the IM70 (Fig. 2). Attach using the provided screws. Making sure that there is a good fit between the IM70 and the cooler, screw the self drillers into the cooler to lock it into place. Repeat for opposite side. Install the perforated grill removed previously to the rear of the IM70.

Note: If this unit is mounted to another unit besides an Ultracool 51 or 71 series unit, you will need to purchase separately a 51 series perforated grill (part #222130-078).

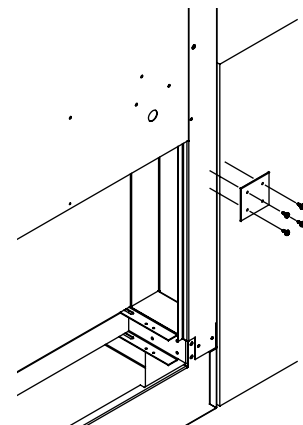

Electrical Installation

⚠ WARNING: Disconnect all electrical service that will be used for this unit before you begin the installation.

- **Remove junction box.** The electrical junction box is located inside the unit above the inspection panel door. Remove two screws and slide the junction box down to gain access to wiring (Fig. 3).

- **Hook up electrical.** Electrical hook up should be done by a qualified electrician, so that all electrical wiring will conform to your local standards. This unit is supplied with a 120V pump and fan motor. See figure 4 for the wiring diagram.

⚠ WARNING: Make sure the cooler cabinet is properly grounded to a suitable ground connection for maximum safety.

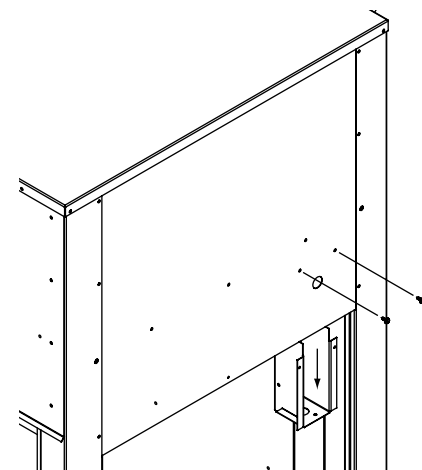

Wiring Diagram

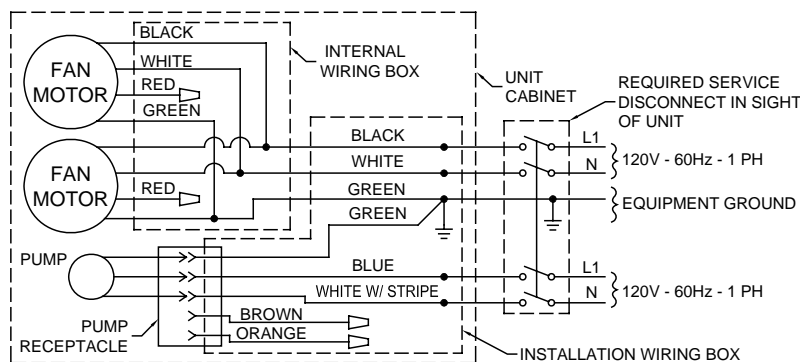

Fig. 4

Water Connection

- **Install overflow assembly.** Place drain nipple through the hole in the bottom pan, with the rubber washer between the pan and the head of the drain nipple (Fig. 5). Screw on nut and draw up tight against bottom of pan. Insert the overflow pipe in the nipple to retain water. The overflow pipe may be removed to drain the pan when necessary. A garden hose may be screwed onto the drain nipple to drain water away from your unit.

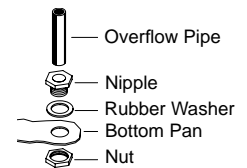

Fig. 5

- **Connect water supply line.** Find the closest supply of water. Run 1/4" tubing from the unit to the water supply. You may use a saddle valve (Fig. 6) to connect 1/4" tubing to the cold water supply or a Sillcock and water valve connected to an outside faucet (Fig. 7). Place the nut and ferrule on the tubing and tighten the nut until water tight. Insert the tubing into the float hole of the corner post. Remove the perforated grill if installed to have access to the float. Attach the tubing to the float using a nut and ferrule. Tighten until water tight. **IMPORTANT:** Do not connect the water supply to any soft water applications. Soft water will cause corrosion and decrease the life of the unit.

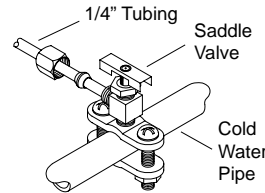

Fig. 6

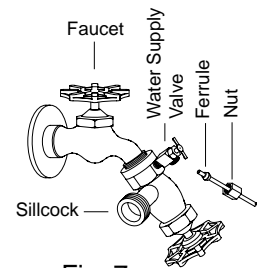

Fig. 7

- **Fill pan.** Allow water to fill to approximately 3" in the bottom pan and adjust the float to maintain this water level. This can be accomplished by bending the float rod.

Maintenance

⚠ WARNING: Before doing any maintenance be sure power is off. This is for your safety.

Spring Start-Up

- **Clean heat exchanger.** Clean the inlet face of the heat exchanger with a garden hose. Remove any obstruction and lightly clean any scale buildup. To clean the top of the heat exchanger, remove the top pan. Remove the media brackets holding the filters in place and remove the filters. Cover up the blower housings so no water comes into contact with the motors. Clean with a hose, removing any obstruction and scale buildup.
- **Clean or change filters.** There is a 3 piece filter set located under the heat exchanger. Remove the inspection panel to access these filters. Remove the filters and clean out the openings with a garden hose. Clean off the face any scale or other obstruction to the passages. Slight scraping may be required to remove hardened scale. There are also mist eliminating filters above the water distribution system. Remove the top pan to gain access to these mist eliminating filters. The media brackets will need to be removed before removing the mist eliminating filters. If cleaning the mist eliminating filters while in the unit, make sure to cover the fan blower housings so that water does not come in contact with the motors. The filters should be replaced after 5 years or when necessary.
- **Clean pump.** Periodic cleaning of the pump will prolong the life and efficiency of the pump. For your safety, make certain the unit is disconnected from the power source before servicing pump. Remove the pump from the pump mount. Refer to figure 8 for disassembling the pump. **DO NOT** open the sealed portion of the unit or remove housing screws. Remove the intake screen. Remove the volute mounting screws. Lightly clean any corrosion or debris which may clog the impeller. Use a brush and penetrating oil and lightly scrape to remove encrusted material. Turn the impeller by hand to make sure it turns freely. After cleaning, reinstall in reverse order. Do not forget to replace the water delivery tube onto the pump outlet.

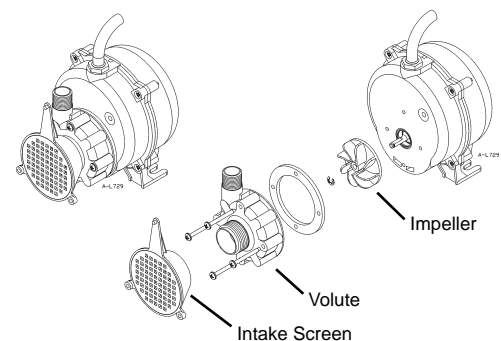

Fig 8

- **Clean bottom pan of any debris.**

Winter Shut-Down

- **Drain water.** Always drain all of the water out of the unit and water supply line when not in use for prolonged periods, and particularly at the end of the season. Keep the water line disconnected from both the unit and water supply so that it does not freeze.
- **Unplug pump.** When cooler is not used for extended periods unplug the pump from inside cooler.
- **Cover unit.** To protect the life of the finish, a cover for the unit is suggested in extended periods of non use.

Replacement Parts List

When ordering parts, please be sure to furnish the following information on all orders. Failure to do so may delay your order.

1. Cooler model number
2. Cooler serial number
3. Description and part number
4. Date of purchase

<u>No.</u>	<u>Description</u>	<u>IM70</u>
1.	Top Pan	222150-001
2.	Bottom Pan.....	322150-002
3.	C-Channel Bracket (2).....	216150-001
4.	Inlet Panel	222150-006
5.	Grill Insert Panel.....	222150-013
6.	Left Side Panel	222150-005
7.	Right Side Panel.....	222150-010
8.	Inspection Panel.....	222150-016
9.	Outlet Panel.....	220150-001
10.	Corner Post, Outlet.....	222150-003
11.	Corner Post, Inlet	222150-004
12.	Side Filler Panel	222150-009
13.	Outlet Support Bracket	220150-003
14.	Inlet Support Bracket.....	220150-004
15.	Media Bracket (4).....	222150-007
16.	Media Filler Panel.....	222150-015
17.	Water Distributor Support Bracket.....	222150-008
18.	Pump Mounting Bracket	220150-002
19.	Pump	110437
20.	Float Mounting Bracket	222150-014
21.	Float Valve.....	FL-C
22.	Squaring Bracket.....	220150-005
23.	Heat Exchanger.....	110140
24.	Filter Pad	310105-101
25.	Mist Eliminator Filter Pad	310105-201
26.	Blower Housing (2).....	324102-005
27.	Blower Wheel, Left (2).....	110747
28.	Blower Wheel, Right (2)	110748
29.	Blower Motor (2).....	110441-C
30.	Fan Motor Junction Box	281004-002
31.	Receptacle, Pump	110361
32.	Electrical Junction Box	322009-004
33.	Rain Guard Kit.....	322150-011
34.	Water Delivery Tube	310717
35.	Water Distributor Assembly	3D-29
36.	Nozzles (8)	110141
37.	Over Flow Assembly.....	3OA-2
38.	Connecting Bracket (2).....	220150-006

NOTE: Standard hardware items may be purchased from your local hardware store.

Parts Drawing

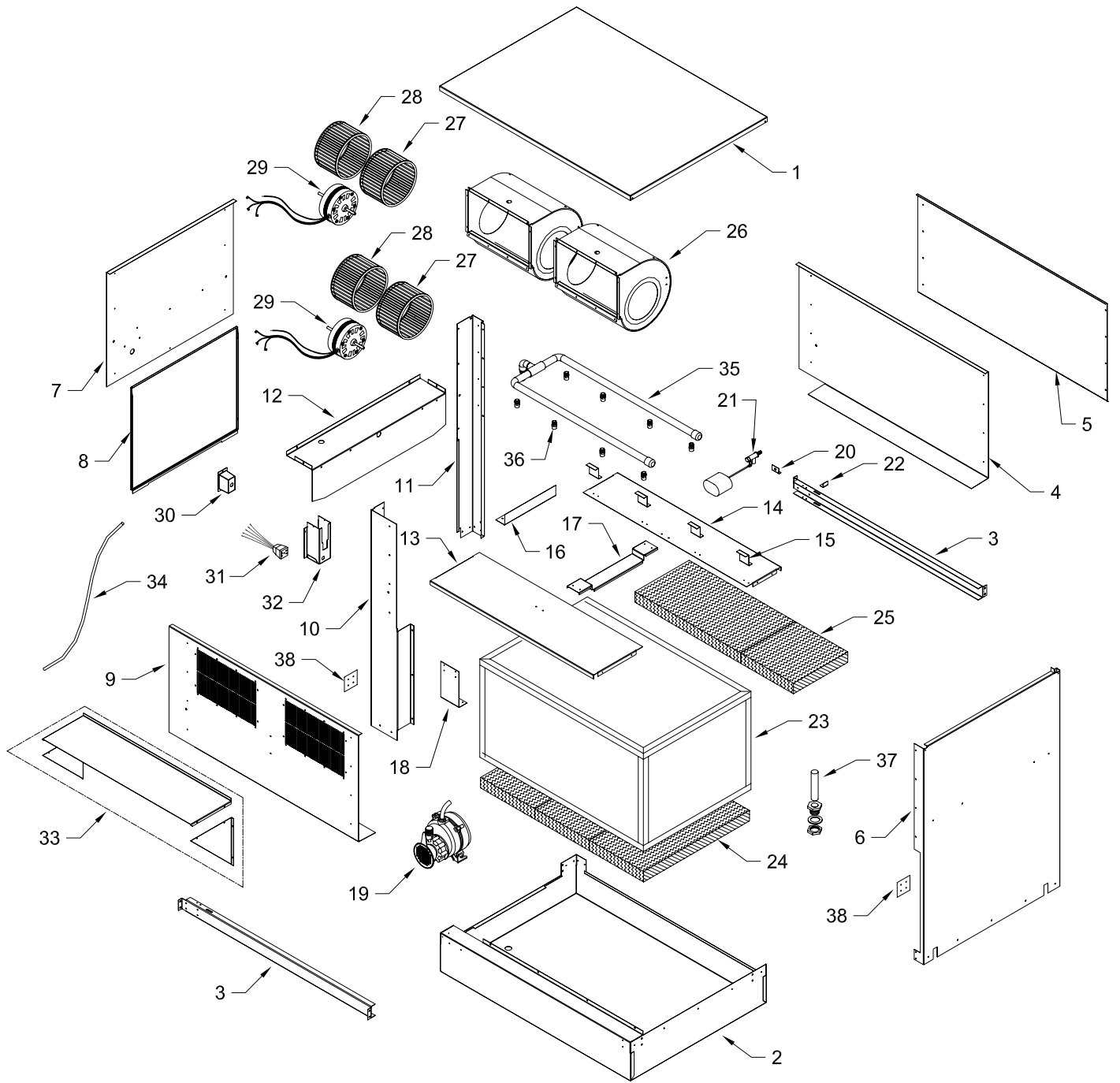

Specifications

Model	Voltage	Total Fan Motor Amperage	Pump Amperage	Approx. Reservoir Capacity	Weight (Lbs.)	
					Shipping	Operating
IM70	115 V	*8 Amps	1.5 Amps	17 Gal.	240	377

* Motor amperage is for 2 motors.

CHAMPION COOLER LP
5800 Murray St.
Little Rock, AR 72209
(800) 643-8341

www.championcooler.com