

Item	P/N	Description
1	516144	Retainer-Vertical
2	504167	Top Support
3	523159	Top
4	512544	Water Distributor
5	524295	Grommet
6	524088	10" CEL-dek
7	524087	12" CEL-dek
8	523158	Side
9	523160	Bottom
10	514593	Polyester Filter
11	504166	pocket
12	589096	Pop rivets
13	524099	Cap
14	514028	Distributor pad

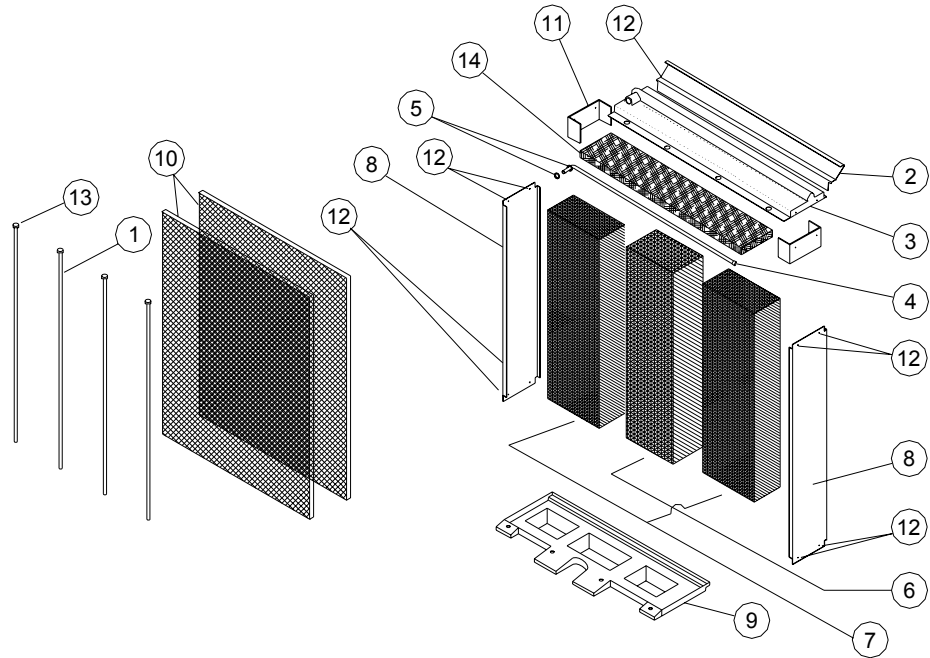

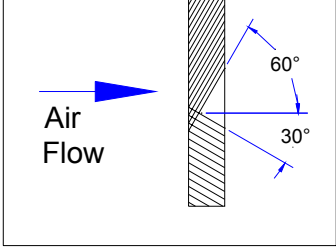
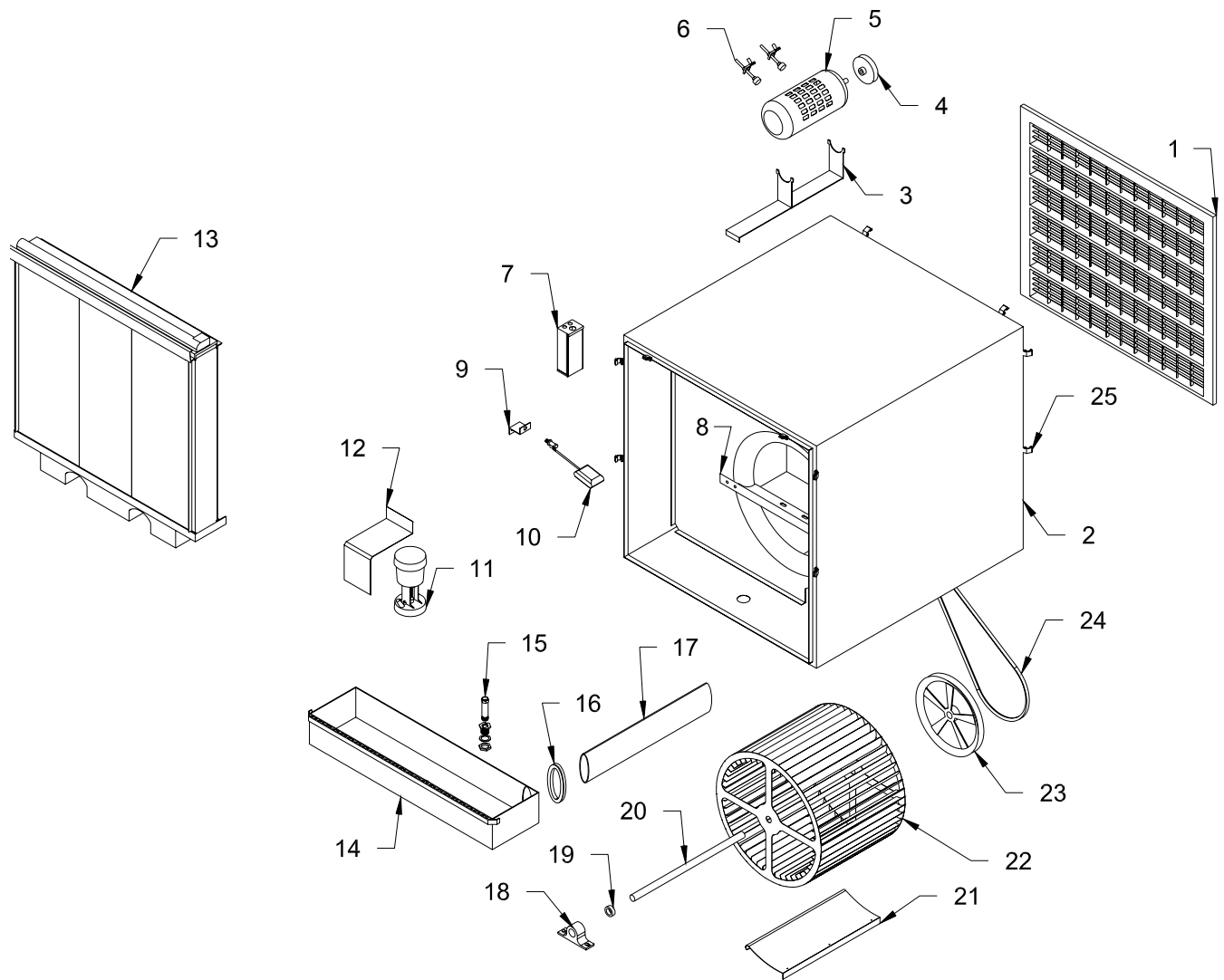

Item	Description	Qty	Part Number	Item	Description	Qty	Part Number
1	Grill	2	29738	14	Right reservoir	1	32030-20
2	Cabinet	1			Left reservoir	1	32030-10
3	Motor mount	1	590509	15	Overflow assembly	1	515100
4	Motor pulley	1	Sold separately	16	Grommet	2	31984
5	Motor	1	Sold separately	17	Cross over tube	1	31985-02
6	Motor adjustment assy	2	512221	18	Bearing	2	583004
7	J box	1	50425	19	Set collar	2	524331
8	Bearing angle	2	514902	20	Shaft	1	516132
9	Float bracket	1	514697	21	Blower cutoff	1	30167
10	Float	1	524198	22	Blower wheel	1	30323
11	Pump (115V)	1	506657	23	Blower pulley	1	583145
	Pump (230V)	1	506658	24	Belt	1	Sold separately
12	Pump bracket	1	70547	25	Grill clip	8	30105
13	Module assembly	2	515251				